



— A COLLABORATION FORGED FOR THE PURPOSE OF —

Empowering South Africa's Youth Through Skills & Employment

"Building the workforce that rebuilds our nation."



THE CHALLENGE

01

UNEMPLOYMENT



02

POVERTY



03

INFRASTRUCTURE



04

INSECURITY
& CRIME



DESPITE THESE CHALLENGES, THE **UNTAPPED POTENTIAL**
OF YOUTH REMAINS A **CRITICAL RESOURCE** FOR
SUSTAINABLE COMMUNITY TRANSFORMATION.

Youth unemployment ~59,93%

**Economic Decline
& Reduced GDP
Growth**



**Lack of Skills
versus the market
Demand**



**Discouraged work
seekers & Skills
Erosion**



**Crime & Social
Instability**





INFORMAL SETTLEMENTS

WHERE MANY CALL HOME



REALITY
FOR
THOUSANDS



BEYOND
THEIR CONTROL
INDIVIDUALLY



SADLY NEGATIVELY PERCEIVED



HOSTS UNTAPPED POTENTIAL

THE RIPPLE EFFECTS

BEYOND INFORMAL SETTLEMENTS



**ILLEGAL DUMPING AND
WASTE OVERFLOW**



**INCREASED HEALTH AND
ENVIRONMENTAL RISKS**



**DERELICT AND
ABANDONED INFRASTRUCTURE**





FORMAL HOUSING

RATE PAYERS PERCEPTION & REACTION



COMPLACENCY
TO PARTICIPATE



NON-ACCEPTANCE OF
INCREASED TARIFFS



ILLUSION THAT THINGS
WILL NOT IMPROVE

HOW DO INVESTORS THINK?



SECURITY & STABILITY
Investors seek safe, stable environments.



SERVICE DELIVERY & INFRASTRUCTURE
Reliable services, infrastructure that works, and efficient systems.



ECONOMIC & INVESTMENT ATTRACTIVENESS
Strong economies, growth opportunities and healthy business ecosystems.



CAPE TOWN – FIRST

- Strongest property market in SA
- Best-performing municipality & governance
- High investor confidence & development pipeline
- Thriving business, tech & global hub



JOBURG – SECOND

- Economic powerhouse of South Africa
- Largest GDP contributor
- Strong commercial & financial activity
- **BUT** concerns around safety, infrastructure pressure & reliability



DURBAN (KZN) – LAST / HOLD

- Significant infrastructure potential
- Service delivery challenges, inefficiencies & red tape
- **Lower investor confidence** despite strong opportunity



CAPITAL DOES NOT FOLLOW POTENTIAL – IT FOLLOWS CONFIDENCE.

WHERE **CONFIDENCE** EXISTS, CAPITAL FLOWS.

This is where the
NXT GEN
FOUNDATION
comes in

WHO WE ARE



We are the youth of **NXT GEN Foundation NPC**.
We are not observers of the crisis — we are living within it.



We represent a generation facing a growing **skills and employment gap**,
and a widening disconnect between **communities** and **the Municipality**.



We have come together — under mentorship,
but **driven by youth** — to take responsibility
for changing this reality.



**We are the first leadership core group
you see today.**
And we are here to build what comes next.



MEET THE TEAM



WHAT IS OUR CITY'S CHALLENGE

The challenge is
not just unemployment —
it is **MISALIGNMENT.**



A gap between
development and **execution**



A gap between
municipality and **communities**



A gap between
investors and **confidence**



A gap between
skills and **opportunity**



While many
national issues
dominate attention,
this crisis continues
to grow quietly —
impacting **economic
participation,
redevelopment,
and long-term
sustainability.**

If not addressed,
it will continue to
hold our city back.

WHAT IS OUR VISION

We do not want to develop youth only to serve **external markets** — or to see our skills **leave our country**.

We want to retain, grow, and multiply skills locally.



Build a strong, scalable **youth leadership core**



Fast-track skills into **real economic participation**



Rebuild **confidence** in our city and its future



Align all stakeholders in a **shared purpose**



We believe meaningful change happens when **municipality, investors, and communities** move together — as one.

WHAT IS OUR **MISSION**

Our mission is to become a **critical link** in rebuilding our city.



PROVIDE & FACILITATE SKILLS DEVELOPMENT



CREATE REAL JOB OPPORTUNITIES



UNLOCK DEVELOPMENT POTENTIAL



REGAIN INVESTOR CONFIDENCE



REBUILD KWAZULU-NATAL

WE WILL DO THIS BY:



Unlocking stalled and underutilised **development opportunities**



Supporting **investor confidence** restoration



Positioning **youth** as active contributors to the economy



Through strategic collaboration with the Municipality, we aim to accelerate **service delivery**, strengthen **development pipelines**, and ensure that **youth inclusion** becomes a **real outcome** — not just a policy.

OUR GOAL

We want to turn potential into productivity.



**GRAB
CANDIDATE YOUTH**
Identify. Engage. Inspire.

UPSKILL THEM
Train. Develop. Empower.

**PLACE THEM INTO
REAL PROJECTS**
Opportunities. Experience. Impact.



FROM **POTENTIAL** TO **PRODUCTIVITY**. FROM **POSSIBILITY** TO **PROGRESS**.



INTRODUCING

PROJECT

40

OUR **FIRST BIG YOUTH DEVELOPMENT INITIATIVE**



EMPOWER

Unlock potential.



EDUCATE

Build skills.



ENGAGE

Create opportunities.





ELEVATE

Drive real change.

40 YOUNG PEOPLE. ENDLESS POSSIBILITIES. ONE STRONGER FUTURE.

OUR PROGRAMME PLAN

1 PHASE 1: INTAKE

-  Recruit **40 motivated** young individuals.
-  Assess their **interests, strengths,** and commitment.
-  Place them into **suitable skills pathways.**

INTAKE

2 PHASE 2: TRAINING

-  Provide **hands-on training** in plumbing, electrical work, office admin, ETC.
-  Deliver **learning through structured workshops.**
-  Reinforce skills via **supervised practical sessions.**

TRAINING

4 PHASE 4: LEADERSHIP & JOBS

-  Place graduates into **internships and entry-level jobs.**
-  Train **top performers** to mentor and support future cohorts.
-  Ensure the program remains **self-sustaining.**

LEADERSHIP & JOBS

3 PHASE 3: PROJECTS

-  Apply skills on **real refurbishment and community projects.**
-  Gain **practical work experience.**
-  Contribute to **improving local infrastructure.**

PROJECTS

HOW WE CONNECT. HOW WE GROW.

Smart intake. Stronger community. Real impact.

1 SMART INTAKE & VETTING A SAFE, FAIR & EFFECTIVE PROCESS

- 1 YOUTH SUBMITS THEIR INFO
- 2 SYSTEM VETS & ANALYZES
- 3 FLAGGED CASES FOR REVIEW



Youth fills in a simple intake form with their background, skills, interests & goals.



Our system checks key criteria and flags any risks or red flags based on set parameters.



Flagged profiles are prompted for further checks by our team before approval.



APPROVED & ONBOARDED



MATCHED TO OPPORTUNITIES



TRACKED, SUPPORTED & EMPOWERED

THE RIGHT YOUTH. THE RIGHT SUPPORT. THE RIGHT IMPACT.

2 OUR PLATFORM: ALL CONNECTED ONE PLATFORM. ENDLESS POSSIBILITIES.



ALL PROJECTS.
ONE PLACE.

Explore all our initiatives and the communities we're building.



EVENTS
CALENDAR

Stay updated on upcoming events, workshops & drives.



JOIN & VOLUNTEER

Sign up, get involved and make a difference where it matters.



YOUR IMPACT
TRACKED

See your journey, hours, contributions & growth.

CONNECTED BY PURPOSE. DRIVEN BY IMPACT.

INTENDED INITIATIVES

A HOLISTIC APPROACH TO BUILD STRONGER, SKILLED, AND SUSTAINABLE COMMUNITIES

INTENDED INITIATIVES

Partnerships, Mentorship & Sustainable Impact

Building strong partnerships and mentorships that drive lasting change.



Skills Development & Capacity Building

Equipping young people with practical skills for the future.



Entrepreneurship & Digital Skills Training

Fostering innovation and digital literacy for economic empowerment.



Community-Led Initiatives & Urban Solutions

Creating smart, inclusive solutions to improve our communities.



Leadership & Project Management Development

Building leadership potential and practical project management capabilities.



Arts, Culture & Creative Expression

Encouraging creativity, preserving culture, and empowering self-expression through the arts.



Health, Well-being & Life Skills

Supporting mental, physical, and emotional well-being for a balanced life.



Wildlife, Conservation & Environmental Action

Promoting awareness, conservation, and responsible environmental stewardship.



Advocacy & Youth Voice Amplification

Amplifying youth voices and advocating for policies that create real impact.



THE RESULTS WE ARE HOPING FOR



40
YOUTH TRAINED
PER CYCLE

70%+
JOB
PLACEMENT



**CITY
BUILDINGS
REFURBISHED**

**CRIME
REDUCTION
IN TARGET AREAS**



STRONGER YOUTH. | SAFER COMMUNITIES. | BRIGHTER FUTURES. | LASTING IMPACT.

NXT GEN INNOVATION HUB



B.O.Q APP

A **simple, real-time** bill of quantities generator that **adapts to the client's selections**. It's linked to an automatically updated **dataset of materials and pricing**, ensuring accurate and current **cost estimates instantly**.



BILL ANALYSIS

A system that can **extract data** from a bill, **deposit into an excel table**, as well as **use formatting** to easily show **problem areas**.

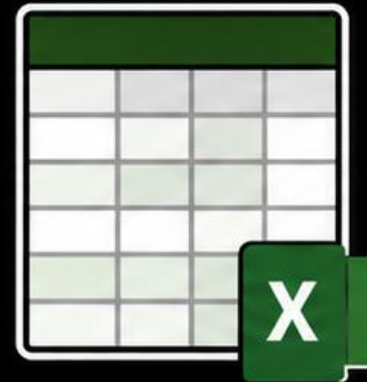

Identify. Analyse. Improve.

INFORMAL SETTLEMENT SOLUTIONS



**DSW CAPACITY IS
OVERSTRETCHED**



Rapidly growing
informal settlements



Waste management
CANNOT KEEP UP



Environmental and
health **risks** increasing



Communities left
without **sustainable**
solutions



**WE
STEP IN
WHERE
SYSTEMS
FALL
BEHIND**



COMMUNITY INCINERATOR SYSTEM BLUEPRINT FOR INFORMAL SETTLEMENTS



MODULAR DESIGN
Easy to assemble
and maintain



**LOW-COST
MATERIALS**
Built for affordability
and durability



**SCALABLE PER
SETTLEMENT**
Adapts to community
size and needs

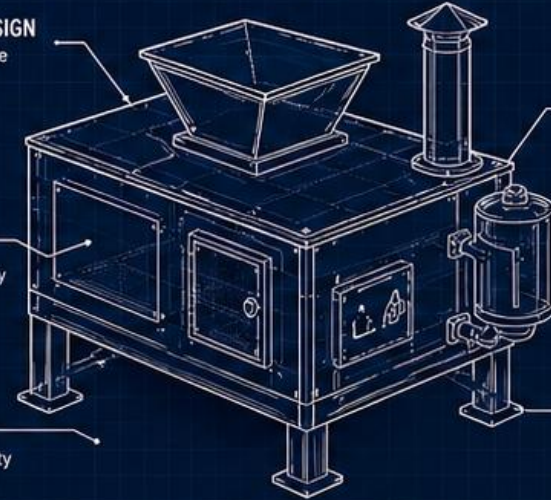

**SAFE
FILTRATION
SYSTEM**
Reduces emissions
and protects
health



**ECO-FRIENDLY
SOLUTION**
Converts waste
responsibly



DESIGNED FOR COMMUNITY OWNERSHIP,
YOUTH IMPLEMENTATION AND LONG-TERM IMPACT

THE IMPACT



**CLEANER
COMMUNITIES**



**REDUCED
WASTE OVERFLOW**



**YOUTH-LED
IMPLEMENTATION**



**SCALABLE
ACROSS KZN**



TURNING NEGLECT INTO OPPORTUNITY
THROUGH **YOUTH-DRIVEN INNOVATION**

THERE IS MUCH WORK TO DO AND WE **CANNOT** DO IT ALONE

BUT WE HAVE **THE YOUNG, FRESH** AND **MOTIVATED MIND** RIGHT HERE RIGHT NOW.

»» WE ASK OF **YOU** TO **JOIN US** ON THIS JOURNEY ««
AS WE BUILD UP TO OUR **FORMAL LAUNCH** IN **JUNE** OF THIS YEAR!

SPACE TO TRAIN



A PLACE TO LEARN,
INNOVATE AND **GROW**.

INTERNSHIPS



REAL WORLD EXPOSURE.
REAL FUTURE **IMPACT**.

BUILDINGS



STRONG SPACES TO
BUILD STRONGER **FUTURES**.

FUNDING



INVEST TODAY.
TRANSFORM **TOMORROW**.

MATERIALS



TOOLS AND RESOURCES
FOR LASTING **CHANGE**.



TOGETHER, WE CAN BUILD. TOGETHER, WE CAN CHANGE LIVES.

JOIN US. SUPPORT US. BACK THE FUTURE.



SPACE TO TRAIN

We envision a dedicated space to host **practical skills training**, serve as our home base, and operate as a **youth center** for our community.



PRACTICAL SKILLS

Hands-on training in high demand skills for real opportunities.



HOME BASE

A central hub for our operations, planning and team.



YOUTH CENTER

A safe, supportive space for youth to learn, grow and connect.



COMMUNITY IMPACT

Built for the community, driven by purpose, creating lasting change.

ONE SPACE. MANY PURPOSES. ENDLESS POTENTIAL.

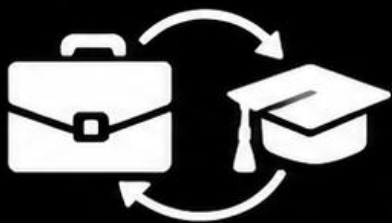

MATERIALS



SUPPORT US WITH **RESOURCES** THIS WILL HELP US EQUIP THE YOUTH WITH THE TOOLS THEY NEED TO LEARN THESE SKILLS.

ITEMS WE NEED



COMPUTERS

Laptops and desktops to support digital learning, research, and skills development.



TOOLS

Hand tools and power tools for construction, carpentry, electrical, and more.



STATIONARY

Notebooks, pens, whiteboards, printers and other essential learning materials.



CLEANING SUPPLIES

Supplies to maintain clean, safe and professional learning environments.



OTHER ESSENTIALS

Safety gear, storage solutions, and items that support daily operations.



YOUR RESOURCES. THEIR POTENTIAL. OUR FUTURE.

Every item makes a difference. Together, we can equip the next generation for success.



INTERNSHIPS



PROVIDING THE OPPORTUNITIES FOR THE YOUTH WE TRAIN TO USE **THEIR SKILLS.**

Our internships bridge the gap between training and real-world experience, helping youth grow their confidence, build their résumés, and launch their careers.



WE HAVE COMMITMENTS FROM CERTAIN PARTIES TO DO THIS, BUT WE ARE **LOOKING FOR MORE.**

We've already secured interest and commitments from several partners who share our vision. Now, we're expanding our network to create even more opportunities for our youth.

WHO WE'VE ENGAGED



PRIVATE SECTOR

COMMITTED

Multiple companies ready to host interns.



EDUCATIONAL INSTITUTIONS

COMMITTED

Partnering to integrate training with real-world experience.



GOVERNMENT BODIES

COMMITTED

Supporting youth development through internship placements.



COMMUNITY PARTNERS

INTERESTED

Exploring ways to create meaningful opportunities.



**MORE PARTNERS. MORE OPPORTUNITIES.
MORE FUTURES TRANSFORMED.**

REAL EXPERIENCE. | REAL EXPOSURE. | REAL IMPACT. | REAL FUTURES.



PROJECTS



LET US, THE YOUTH USE THE SKILLS WE HAVE TO **REBUILD DEGRADED BUILDINGS AS WELL AS OTHER INITIATIVES.**

Hands-on projects. Real impact. Stronger communities.



BUILDING REHABILITATION

Restoring degraded buildings to create safe, usable spaces for our communities.



INFRASTRUCTURE UPGRADES

Improving essential infrastructure that drives long-term community growth.



WHAT WE'RE BUILDING



ROOFTOP GARDEN PROJECT (ABM)

Growing fresh produce, building sustainability, and creating green opportunities.



SKILLS IN ACTION PROJECTS

Real-world projects where youth apply skills, gain experience, and lead change.



COMMUNITY INITIATIVES

From clean-ups to public spaces, we build pride, unity and lasting impact.



OUR SKILLS. OUR COMMUNITY. OUR FUTURE.

FUNDING: WHAT WE NEED & WHEN

EVERYTHING YOU'VE SEEN SO FAR REQUIRES FUNDING TO BECOME REALITY.



WE DON'T NEED THE MONEY JUST YET.

We are currently finalizing key actions and preparations to ensure we launch with impact and efficiency.

IMMEDIATE PRIORITY (NOW)



EQUIPMENT & SPACE

Essential to start training, building and creating.

MAJORITY OF FUNDING (CLOSER TO LAUNCH)



STIPENDS FOR TRAINEES

Our biggest funding need will be stipends for trainees to support their commitment and journey. This will be most critical as we approach our formal launch in **June**.

FUNDING WILL SUPPORT:



TRAINING & CAPACITY BUILDING

Workshops, materials, certifications



EQUIPMENT & TOOLS

Practical training and project execution



FACILITY & OPERATIONS

Space, utilities, maintenance



TRAINEE SUPPORT

Stipends, transport, meals, PPE



YOUR INVESTMENT TODAY BUILDS THEIR TOMORROW.

The **right support**, at the **right time**, creates **lasting change**.

BE A PART OF **THE REBUILD**

THANK YOU FOR YOUR TIME



 **PRO DIRECTOR**
MBASA

 **FINANCE DIRECTOR**
TAS

 **MIS DIRECTOR**
DAEMEAN

 **OPS DIRECTOR**
FUZAIL

SCAN



CONTACT US HERE

-  www.nxtgenfoundation.org
-  info@nxtgenfoundation.org
-  [nxt_gen_foundation](https://www.instagram.com/nxt_gen_foundation)



CONTACT IS HERE
+27 64 525 6483